

**DFM - PINZA PER IL SOLLEVAMENTO TRAVI**  
**DFM - CLAMP FOR LIFTING OF BEAMS**

Pinza progettata per il sollevamento, il trasporto ed il ribaltamento di travi in acciaio. Il design consente di sollevare travi in acciaio (H) sia sulla flangia che sulle estremità superiori della trave.

Clamp designed for lifting and transport of steel beams and plate. Special design makes it possible to lift steel (H) beams on the flange as well as on the upper ends of the beam.

Design leggero per una facile maneggevolezza.  
Lightweight design for easy handling.

Struttura robusta in acciaio al carbonio di alta qualità.  
Tough quality heavy duty welded shell body.

Apertura della bocca fino a 45 mm.  
Jaw openings up to 45 mm.

Portata (WLL) fino a 10 ton (portate superiori su richiesta).  
Working load limit (WLL) up to 10 ton (higher WLL available upon request).

Conforme a EN13155.  
Compliant to EN13155.

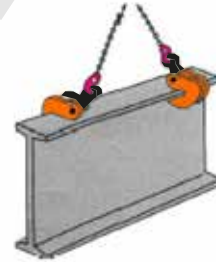

Possibilità di applicare il microchip NFC-RFID (Tech for safety).  
Possibility of applying NFC-RFID microchip (Tech for safety).



**DFM** DFM Pinza per il sollevamento travi  
DFM Clamp for lifting of beams

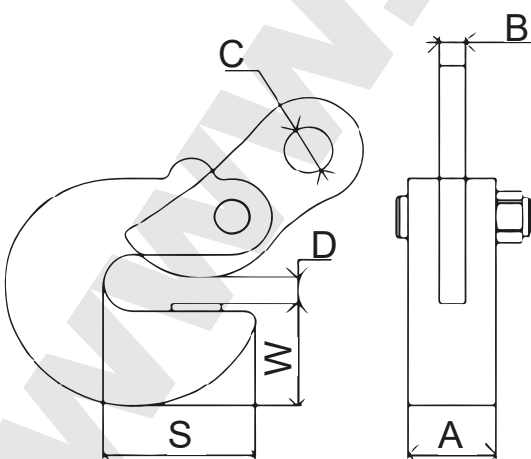

Code	WLL	Apertura Open Size	A	B	C	D	S	W	Peso Weight
	(t)	(mm)	(mm)	(mm)	(mm)	(mm)	(mm)	(mm)	(kg)
<b>DFM01000</b>	1	0-15	40	12	22	15	68	42	2,7
<b>DFM02000</b>	2	0-20	45	16	30	20	80	52	5,6
<b>DFM03000</b>	3	0-30	50	18	37	30	105	65	8